

the **EXTENSION**

A Technical Supplement to Control Network

© 2008 Contemporary Control Systems, Inc.

Examining the BACnet® MS/TP Physical Layer

By George Thomas, Contemporary Controls

Introduction

In our very first Extension article (Volume 1, Issue 1) back in the spring of 1999, we wrote about the EIA-485 standard and the intricacies in applying it. This networking standard remains one of the most popular—being used with several automation protocols that include Modbus, Profibus and BACnet. There is an abundance of transceiver chips from several vendors, and the standard has been very stable with no changes since March of 1998. What we said in the spring of 1999 still applies, but more can be said about this standard as it applies to BACnet MS/TP. BACnet supports several data links and physical layers, but Master-Slave/Token-Passing (MS/TP) is by far the most popular due to its low-cost and reasonable performance. EIA-485 is not a complete physical layer specification so the BACnet specification attempts to address what is missing.

Quick Review of EIA-485

ANSI/TIA/EIA-485-A-1998 is entitled *Electrical Characteristics of Generators and Receivers for Use in Balanced Digital Multipoint Systems*. Although we went into some detail in our original article, we can sum up its attributes as follows:

- It is a physical layer standard and therefore resides in layer 1 of the ISO Open System Interconnection Reference Model.
- It is a half-duplex communications standard that supports up to 32 points on a shared bus with any point being able to initiate a transmission.
- It incorporates differential transmission and receiving techniques over a balanced communications medium in order to greatly improve transmission reliability.
- It is independent of any protocol evidenced by the fact that several automation protocols specify it.
- It does not specify data rate, signal encoding or even the type of symbols used to distinguish a binary “1” from a binary “0.”
- It does not specify the cable to be used or any distance limitation.
- It does not specify connectors to be used, required termination or required fail-safe bias.

To utilize the EIA-485 standard within another communications standard such as BACnet, much of what has not been addressed in the EIA-485 standard

must now be specified in order to have a fully functional specification. MS/TP physical layer details can be found in ANSI/ASHRAE 135-2004 *BACnet—A Data Communication Protocol for Building Automation and Control Networks*.

BACnet MS/TP Physical Layer

In the BACnet standard, the MS/TP physical layer is defined in section 9.2, however, some details remain unspecified. There are three subsections entitled *Medium*, *Connections and Terminations*, and *Timing*. We will discuss all three subsections starting with medium and introduce one issue of importance that is not covered.

Medium

In 9.2.1 it says that shielded twisted-pair cable with characteristic impedance between 100 to 130 Ω shall be used. The capacitance between conductors shall be less than 100 pf per meter (30 pf per ft.), and capacitance between conductors and shield shall be less than 200 pf per meter (60 pf per ft.). Foil or braided shields are acceptable. The maximum recommended segment length is 1,200 meters (4,000 ft.) when conductor diameters are 0.82 mm² (American Wire Gauge 18). The standard then goes on to say that if greater distances are to be obtained or the use of larger diameters is anticipated, then compliance to EIA-485 is still required. Therefore the absolute maximum segment length is not stated, and there is no specific cable specified.

By surveying BACnet manufacturer's equipment, little consistency can be found in specifying cable. Some manufacturers simply quote the BACnet standard and leave the ultimate selection up to the installer. Others specify a proprietary cable using an internal part number. If the choice is up to the installer, what should the installer choose? As the diameter of the conductors increases, the capacitance between conductors does as well. Trying to find low-capacitance 18 AWG cable at a reasonable price is a challenge.

With the popularity of Ethernet and the lower cost of CAT5 cable in a competitive market, there will be a tendency to use CAT5 cable instead. CAT5 cable is widely available having a characteristic impedance of 100 Ω , but it is a four-pair unshielded twisted-pair (UTP) cable. There is a shielded version of 100 Ω CAT5 UTP called Screened Twisted-Pair (ScTP) which is also 100 Ω . This cable should not be confused with IBM's Shielded Twisted-Pair (STP) which is 150 Ω cable well outside the scope of the BACnet standard.

As we will learn later, terminating 100 Ω cable will be difficult due to the lower impedance.

The other approach is to use cable specifically designed for EIA-485 communication. All the major cable manufacturers carry such cables with characteristic impedances of 120 Ω . Shielded versions are available with plenum and non-plenum ratings. But how many twisted-pairs are needed? Looking at Figure 1 you would think one twisted-pair is sufficient and in most cases this would be correct. Figure 1 represents a typical diagram for a 2-wire non-isolated EIA-485 implementation, but there is an implied third wire which is the common ground of all the transceivers. EIA-485 clearly states that “proper operation of the interface circuits requires the presence of a signal common path between the circuit commons of the equipment connected along the balanced interconnecting [media].” This path could be the power supply common or earth connection. It can also be a third wire which will be discussed later when isolated transceivers are introduced.

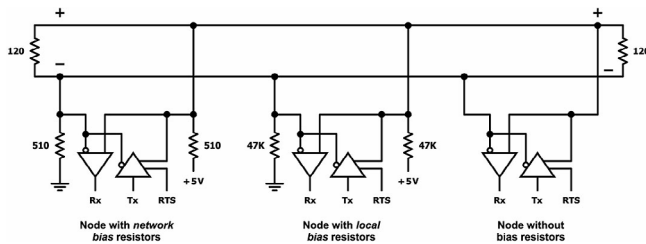

Figure 1. EIA-485 bus from the BACnet MS/TP section showing two types of fail-safe bias.

Connections and Terminations

In Figure 1 you will find the same EIA-485 network, as shown as Figure 9-1 in the BACnet standard, identifying three types of nodes. The node on the right has no fail-safe bias but has applied termination. The middle node has only a weak fail-safe bias which the standard calls local bias. The node on the left has both a stiff fail-safe bias and termination. This bias is called network bias since it is used to bias the entire network. Either one or two applications of network bias are allowed, but if two are used, then they should be located at the two ends of the bus segment. In the text of the standard it is mentioned that a total of 32 nodes are supported over one segment. Those additional nodes would look like the node in the middle with pull-up and pull-down resistors no less than 47 k Ω . The use of local bias is optional. Termination can only be applied at each end of the segment and the value must be 120 Ω \pm 5%. Although a separate bus receiver and bus driver are shown per node, collectively they are referred to as a transceiver.

There are two important parameters that can be found in the EIA-485 standard as well as in transceiver data sheets. The first is the receiver’s undefined input voltage range, and the second is the driver’s minimum drive current.

At the receiver, a differential input voltage from zero to \pm 200 mV is undefined. Voltages beyond this range are defined as being either a logic “0” or logic “1.” The floating of the differential input could yield an

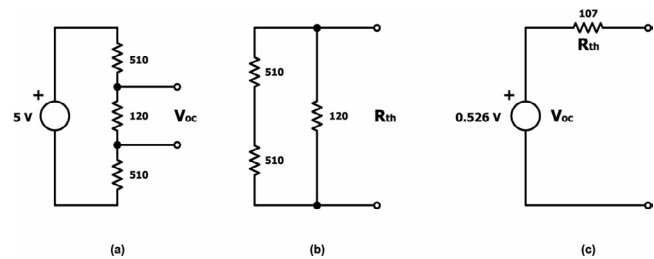

Figure 2. Calculating the equivalent termination resistance and bias.

unpredictable output so some fail-safe bias is provided such as is done to the middle node in Figure 1. A weak bias is applied to guarantee a defined output state of the receiver if the cable is disconnected. A 47 k Ω resistor pulls the non-inverting input high and another 47 k Ω resistor pulls the inverting line low—forcing the receiver output to a logic “1” state which is the *idle* state of the bus. Newer receivers have built-in fail-safe bias eliminating the need for external 47 k Ω resistors. Internal values can be as high as 120 k Ω , but weak fail-safe resistors are useless when the cable is connected and a 120 Ω terminating resistor is applied at the end of the bus segment. The fail-safe bias would immediately collapse below the \pm 200 mV level with the potential of false detection of logic states by the receiver during idle conditions. When the bus is being driven by one of the nodes, fail-safe bias is not an issue since the bus will be in one of the two defined states. When no driver is enabled, the bus becomes idle with a potential risk of false signaling due to noise and ringing on the bus as the bus voltage collapses towards the undefined input region. The use of weak fail-safe bias is only useful when it is desired to have a defined receiver output when no cable is connected to the receiver input.

The input impedance at each terminal of an EIA-485 receiver is no less than 12 k Ω , and this value is called a *unit load*. One unit load is much greater than the typical termination resistor so the termination resistance on the right-hand side is considered 120 Ω . The same is not true on the left-hand side since the 510 Ω bias resistors play a role.

We need to determine the effective termination resistance of the bias/terminator combination which is best done using Thévenin’s Theorem.

What we want to do is to represent the bias/termination network as a 2-terminal network to ease our understanding of the circuit. The first step is to find the open-circuit voltage V_{oc} (Figure 2a) which is accomplished by making a simple voltage divider calculation. This results in $V_{oc} = 526$ mV. The next step is to determine the equivalent impedance of the network by first representing the independent voltage and current sources by their internal impedance. For voltage sources it is infinite ohms and for current sources it is zero ohms. Treating the 5 Volt power supply as a zero ohm resistor in Figure 2b, we determine the equivalent resistance of the series/parallel combination of resistors which yields $R_{th} = 107$ Ω . The Thévenin equivalent circuit is shown in Figure 2c with V_{oc} representing the bias and R_{th} representing the termination.

Notice that the effective termination resistance is not 120 Ω and is not even within the 5% tolerance of the termination resistance called out in the BACnet specification. There is no mention in the BACnet standard as to the acceptable amount of bias. However, from the EIA-485 standard we know it must be greater than ± 200 mV so the 526 mV value appears acceptable.

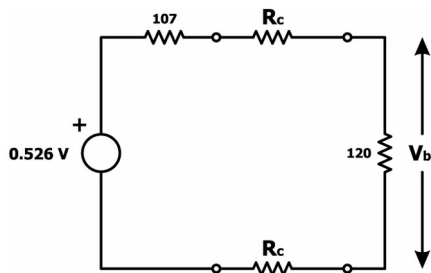

Figure 3. The bias V_b at the end of the segment will be less due to conductor resistance.

The next step is to take the equivalent circuits of both the right- and the left-hand sides and insert the cable resistance (R_c) for the longest possible segment length between these end nodes as shown in Figure 3. For 18 AWG cable the conductor resistance is 6.8 Ω per 1000 ft. so a 4000 ft. run would equal 27.2 Ω . However, since we need to consider the return path the overall resistance is double this amount. Inserting the conductor resistance for R_c equal to 27.2 Ω and doing a voltage divider equation yields a bias voltage (V_b) of 224 mV which is still above the minimum.

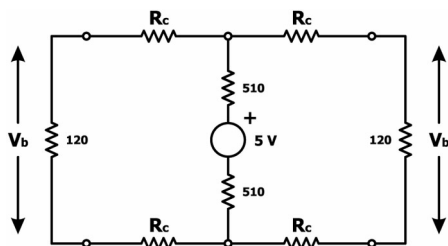

Figure 4. By applying single-point bias at the middle of the segment, adequate bias at the end-points will be maintained.

If we had substituted a lower-capacitance cable with conductor sizes of 24 AWG, the resistance per 1000 ft. jumps to 24 ohms. If we redo our calculations by inserting 96 ohms for R_c , V_b becomes 150 mV which is below the min. Therefore a single point of fail-safe bias at the end of a segment does not guarantee adequate bias at the far-end. It is possible to put the same bias in the middle of the 4000 ft. segment and move the termination resistors to each end of the segment. This would result in the circuit of Figure 4. The value of R_c is cut in half to 48 Ω but there is resistance on both sides of the bias point. Calculating the resulting bias at each end would yield a V_b of 266 mV which is above the minimum while using this low-capacitance cable. However, it should be noted that with a single point of bias, bias is not uniform over the entire bus segment due to voltage drops along the segment.

Look at Figure 5 where bias is applied at both ends of the segment. Because of the equal bias potentials at the two end-points, there are no voltage drops along the segment, meaning that the same 526 mV of bias exists all along the bus segment. Of course, the assumption here is that the middle nodes have infinite impedance when we know they represent approximately one unit load. If we had applied local fail-safe bias to all 30 middle nodes, an additional loading of four unit loads would be realized. This added loading will create a droop in bias in the middle of the bus segment assuming equal distribution of nodes, but it is clear that applying redundant bias at the end points is superior to a single point of bias.

Adding bias of any form increases the bus loading so we must again refer to the EIA-485 specification. A driver must be able to generate no less than 1.5 V into 60 Ω along with 32 unit loads. Most commercial transceivers can do better than that, but it is best to keep the equivalent termination resistance at 120 ohms each (two in parallel equals 60 Ω) and increase the local bias resistors as much as possible.

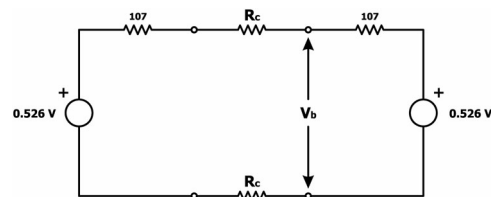

Figure 5. Applying equal bias at the end-points would theoretically eliminate any voltage drops due to conductor resistance.

Instead of the 510/120/510 combination used in the BACnet specification, a 720/130/720 combination provides a 120 ohms effective termination with 414 mV of bias. Unit loading can be reduced as well by incorporating 1/2 load and 1/4 load receivers.

Timing

In subsection 9.2.3 it is mentioned that non-return to zero (NRZ) encoding is used. Since NRZ encoding utilizes the complete bit time for each symbol, the baud rate and data rate are the same. The standard mentions an upper limit of 76,800 bps, but practice has shown that higher speeds are frequently used. To accomplish these speeds a closer attention to cable selection is required.

Isolated EIA-485 Circuits

There is no mention in the BACnet standard of isolated EIA-485 circuits other than the comment that for those segments that span between buildings there shall be at least 1500 V of electrical isolation between EIA-485 signal conductors and digital ground. In order to meet this requirement we would need an isolated EIA-485 design which we call a 3-wire transceiver. In Figure 6, the typical 2-wire transceiver is shown with an implied third wire being the circuit common. If all of the 2-wire nodes shared the same power supply source, then there would be a consistent common reference between all nodes and no need to run a third wire between circuit commons.

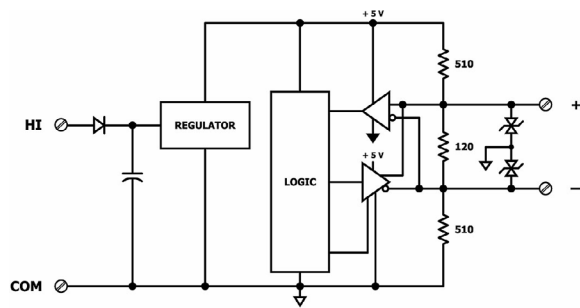

Figure 6. A 2-wire non-isolated EIA-485 transceiver has an implied third-wire which is circuit common.

If the nodes were distant from one another and operating from different power supplies, then either a third-wire would need to be run between circuit commons or each circuit common would need to be connected to earth or bonded to a common metal infrastructure. This is to insure that the common-mode limit (± 7 V) is not exceeded, thereby damaging devices. Providing a third wire between circuit commons is not encouraged since ground loops can result and the potential that an undersized third wire will carry fault current damaging the wire and possibly the equipment. Granted, protection circuitry can be added to each node, but all protection is limited. If all of these solutions are not acceptable, an isolated transceiver is necessary.

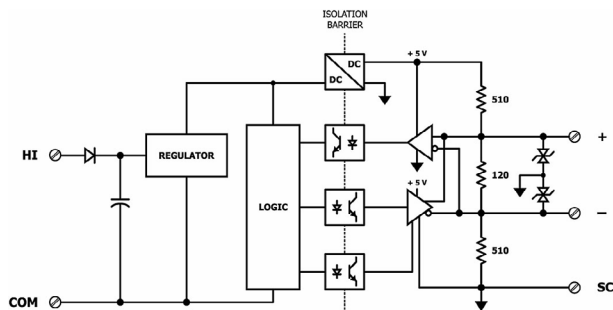

Figure 7. A 3-wire isolated EIA-485 transceiver has its own signal reference (SC) which must be connected to other 2-wire or 3-wire devices.

In Figure 7 a simplified schematic of the isolated EIA-485 transceiver is shown. Notice that the transceiver common (SC) is electrically isolated from the power supply common (COM) through the use of opto-isolators and an isolated DC-DC converter. By proper choice of components and attention to printed circuit board layout, obtaining 1500 V of isolation from the remainder of the device's circuitry is possible.

By providing an isolated EIA-485 transceiver there is less opportunity of damage due to high common-mode voltages, but there is still a risk.

Surge suppression is applied between the differential inputs and between each input and ground. Since the transceiver is electrically isolated, the transceiver's circuit common must be brought out for connection to the other devices on the MS/TP network. This is accomplished by pin SC. The differential pair is labeled + and - and corresponds to the same designations in the BACnet MS/TP standard. This requires a three-wire connection to the MS/TP network. When connecting other isolated MS/TP devices there is no problem since each device requires a 3-wire connection. Just make corresponding connections. For non-isolated MS/TP devices, usually only a 2-wire connection is provided. The third wire is the power supply common. In this situation, the SC connection must be made to the power supply common of the non-isolated device. A proposed change to the BACnet standard to include details on isolated nodes is under consideration.

Summary

EIA-485 is a popular physical layer standard which is widely used in automation industries. However, by itself it is not a comprehensive standard. The BACnet MS/TP standard tries to fill in some of the necessary information that is missing while still leaving certain decisions up to the user. In order to fully understand the intricacies of the MS/TP physical layer you must consult both standards.

References

"Understanding EIA-Networks," *The Extension*, Volume 1, Issue 1 Spring 1999, Contemporary Control Systems, Inc.

ANSI/TIA/EIA-485-A-1998 Electrical Characteristics of Generators and Receivers for Use in Balanced Digital Multipoint Systems, March 1998, Telecommunications Industry Association

ANSI/ASHRAE 135-2004 BACnet—A Data Communication Protocol for Building Automation and Control Networks, 2004, American Society of Heating, Refrigerating and Air-Conditioning Engineers, Inc.